

name expansion of aircraft deicing fluid storage tank farm at the Hamburg Airport

owner Flughafen Hamburg GmbH

place Hamburg Airport

duration begin June 2011
end October 2012

In order to cover to increasing demand of aircraft deicing fluid at Hamburg Airport the storage tank farm has to be expanded. The storage capacity of currently one day and a half will be doubled to three days.

- 4 tanks, 30,000 liter (7,800 gal) each, for aircraft deicing fluid type 1,
- 4 tanks, 30,000 liter (7,800 gal) each, for aircraft deicing fluid type 2,
 - 1 tank, 20.000 liter (2,500 gal), for deicing fluid Pre-Mix,
 - 2 tanks, 30.000 liter (7,800 gal) each, hot water storage.



View of aircraft deicing fluid storage tank farm

services

wolf engineers + consultants has been awarded for design development, specification writing, and site inspection services of the expansion of the aircraft deicing fluids storage fuel farm:

industry + production - aviation
 featured projects



energy + power
 water + sanitation
 agriculture
 industry + production
 building services

wolf engineers + consultants has been awarded for design development, specification writing, and site inspection services of the expansion of the aircraft deicing fluids storage fuel farm:

- stainless steel pipe works through DN150 (6 in), storage tanks for hazardous materials
- lightning protection, power supply, instrumentation, automation, lighting
- civil works + steel framework
- rehabilitation of retention system for firewater, hazardous materials, and concrete foundations

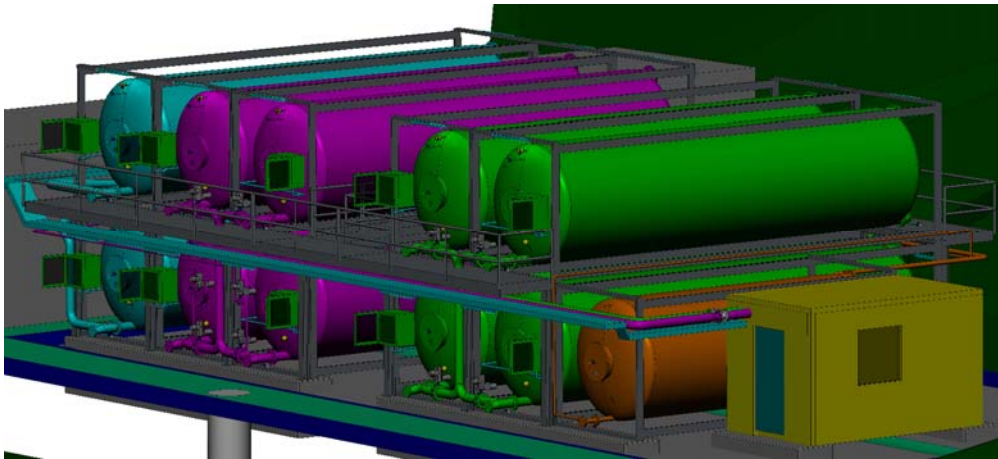

Design model aircraft deicing fluid storage tank farm



Tankcontainer delivery

industry + production - aviation
featured projects



energy + power
water + sanitation
agriculture
industry + production
building services

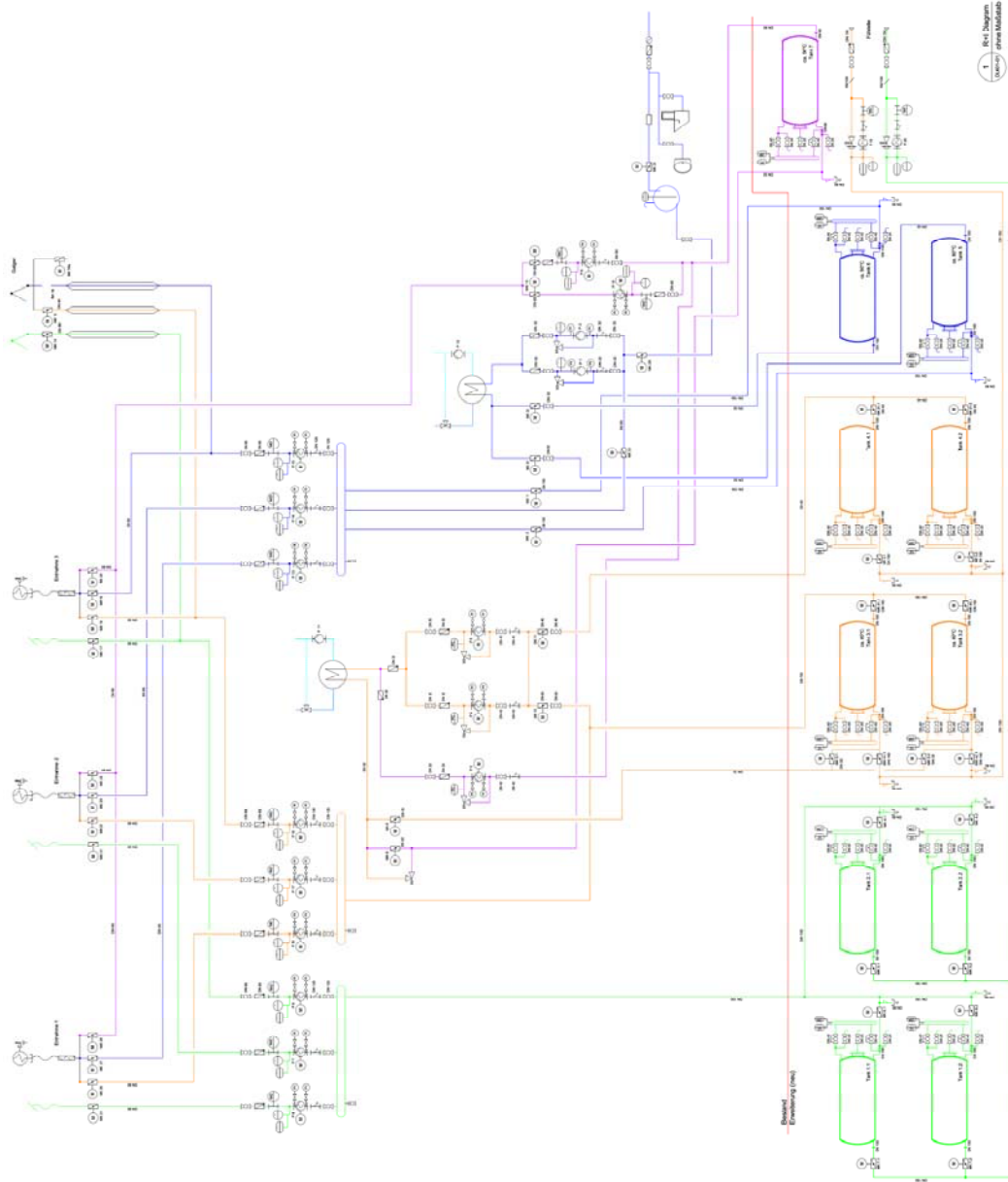

P+ID aircraft deicing fluid storage tank farm

industry + production - aviation featured projects



energy + power
water + sanitation
agriculture
industry + production
building services